



WT-FRT62XC-1213

Congratulations on the purchase of your Australian made Wedgetail Roof Rack product.

Please read and follow the instructions carefully to ensure correct fitment.

Contact us if any parts appear missing, incorrect, or damaged.

Clean the roof prior to fitting the roof racks.

Tools Required:

- T-20 Torx
- T-25 Torx
- 8mm socket
- 6mm socket
- 13mm spanner
- 17mm spanner
- 6mm Allen key
- 5mm Allen key

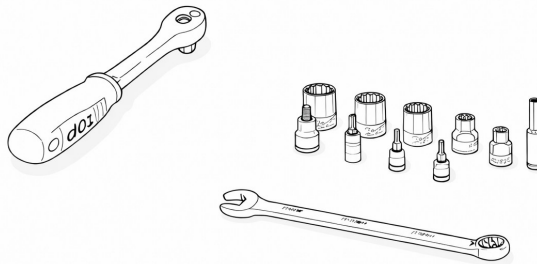

Wedgetail Rails and Platform Fitting Instruction

To suit Ford Ranger T6.2 Extra Cab 2022—Current



WT-FRT62XC-1213

Kit Content

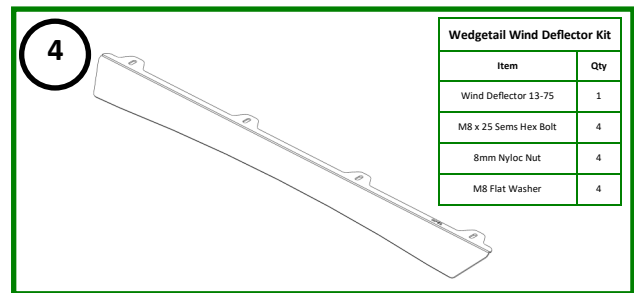
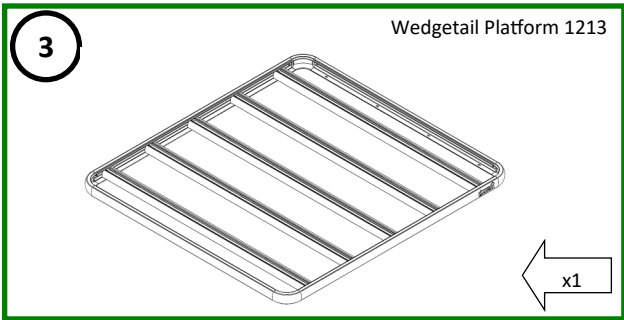
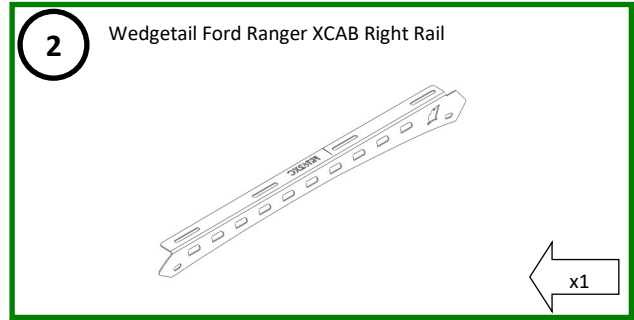
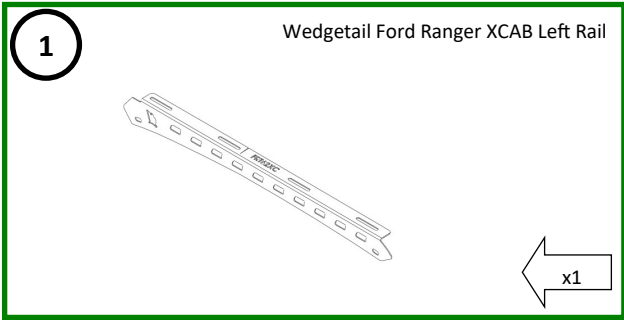

Removing Interior of Vehicle

1

Remove door rubbers

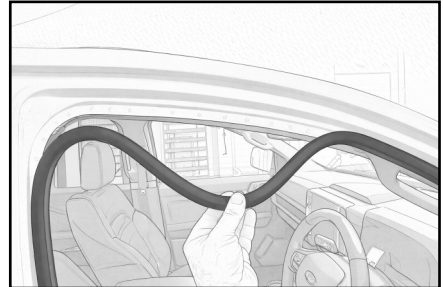

2

Remove the Pillar Grab Handles

Tool required: 6mm socket

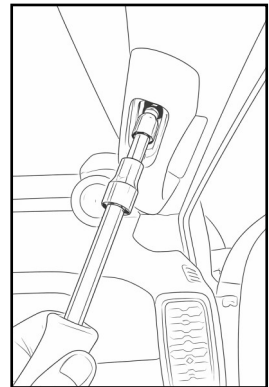
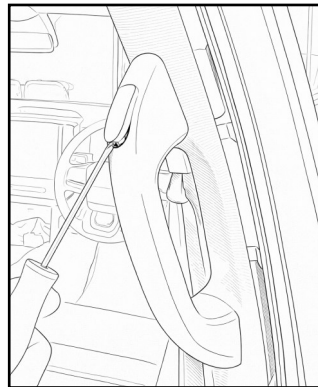

3

Remove the Roof Pillar Grab Handles

Tool required: T-20 torx bit

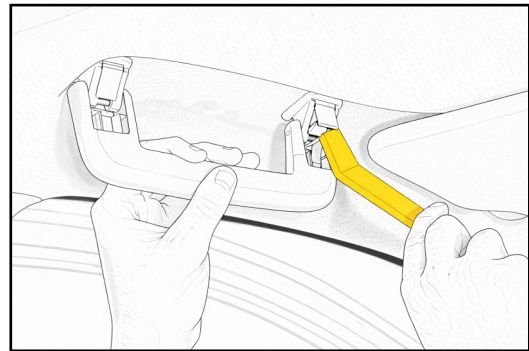

4

Use lever to remove the sun visor cove panel and expose T-20 torx fixings

Remove visor and clips using: T-20 torx bit

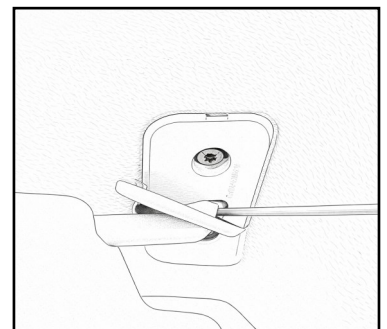
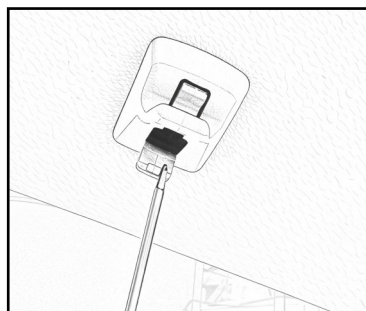

Removing Interior of Vehicle

5

Remove the roof center console

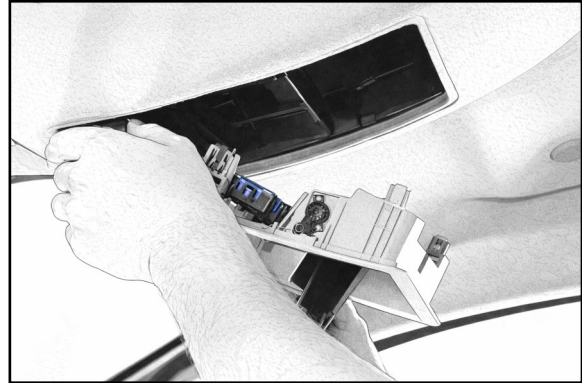

6

Remove the rear seat panel taking care not to damage clips

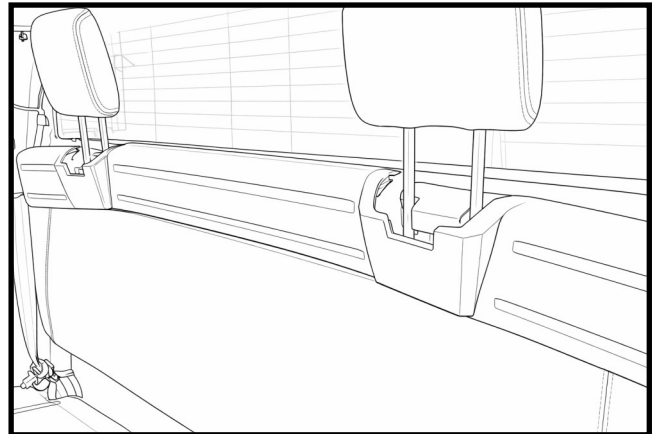

Removing Interior of Vehicle

7

Remove the A pillar
taking care not to damage clips



8

Remove the C pillar
taking care not to damage clips

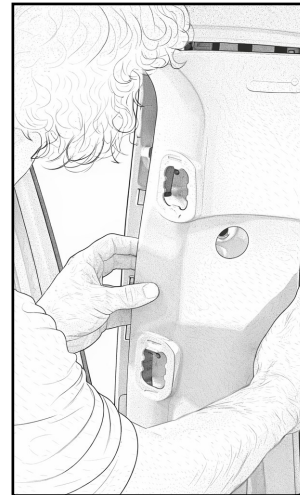

9

Remove all other plastic covers
and trims that prevent access to
the roof underside if required

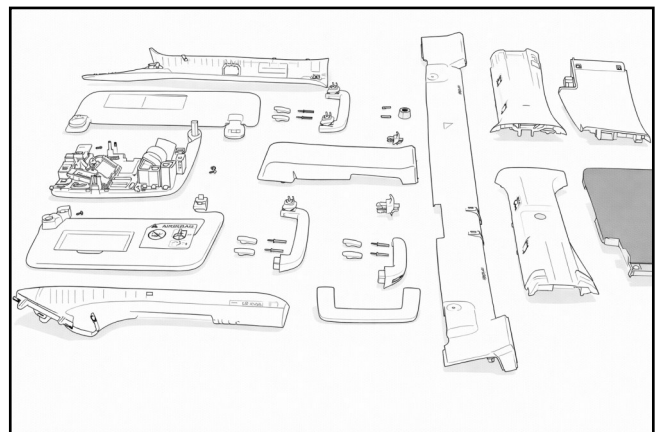

Removing the factory roof rails

10

Drop the roof headlining

***Some installers chose to install sound deadening in the underside of the roof to reduce wind noise and vibration. This can be done by choice at this point if the headlining is fully dropped.*



11

Loosen the metal bracket at the rear to gain access to the bolt

Remove factory ditch rubber retaining nut from the underside.

Tools required: 8mm hex deep socket

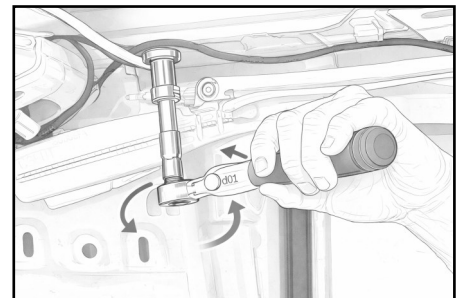
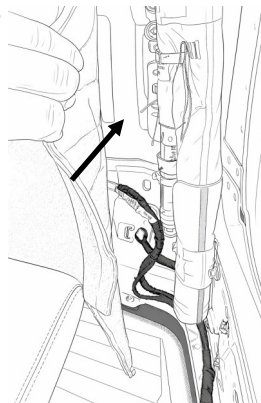

12

Peel off the gutter rubber

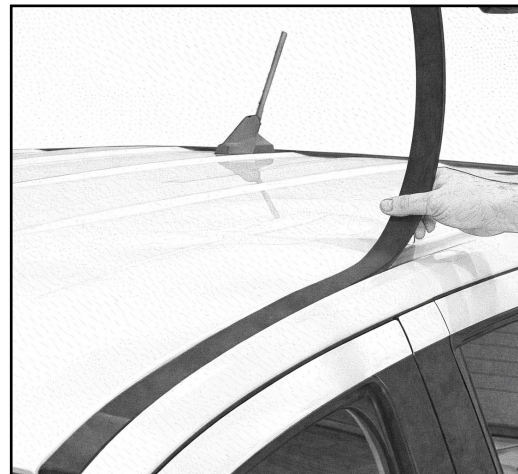

Mounting Lug and Rail fitment

13

- Clean the gutter using the micro fibre cloth
- Apply silicone on all the roof channel mounting holes to prevent any water ingress.
- Only front and rear holes to be used. All other holes to be plugged

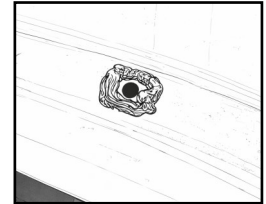

14

- Use pliers to remove volcanised 6mm fastener from the underside of rubber required force.
- Use Shears or a knife to trim away underside of rubber so it sits flush over the top of mounting bracket and bolts

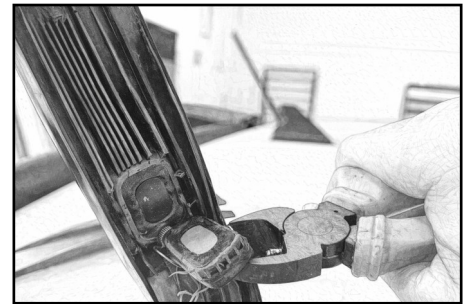

15

- Place Lugs into position and install using 8mm socket head, 8mm nyloc nut and flat washer underneath nut.
- Cover the lug with the rubber
- Secure rubber in place with sealant
- Use masking tape on ends of rubber strip to secure until sealant is cured
- Tools required: 5mm Allen key 13mm spanner

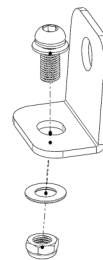

16

- Place wedgetail rails onto lugs and fasten M10 socket bolt and nut
- Tools required: 17mm spanner and 6mm hex key

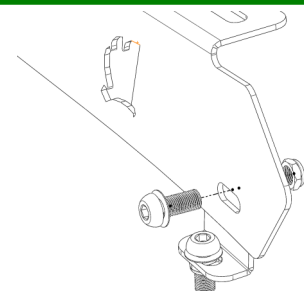

Wedgetail Rails and Platform Fitting Instruction

To suit Ford Ranger T6.2 Extra Cab 2022—Current



WT-FRT62XC-1213

17

- Attach the channel nuts to the top of rail.
 - Fit 10mm Bolt / Split washer/ Flat washer / Channel Nuts to the top of rail.
- Channel nuts to the top as shown in the following diagram
- Tools required: 17mm spanner

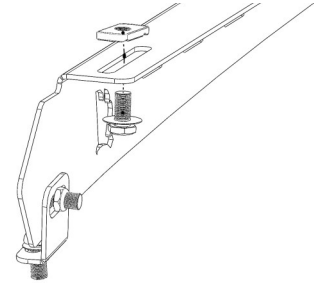

Assemble the Wedgetail Platform to the rails

18

- Place the Wedgetail Platform on the rails (Wind deflector mounting towards the front of vehicle), then spin the channel nuts 90 degree in the channel on the underside of the rack till they lock into the channels. Do not tighten fully.

19

- Centralize the rack side to side (using a tape measure) on the wedgetail rails.

20

- Fully tighten remaining bolts in the following order:
 1. Rails to the lugs
 2. Rails to platform
 3. Attach wind Deflector.

NOTE-Ensure the channel nuts are 90 degrees to the channels.



Check fastenings are firmly tensioned at regular intervals.

Do not overtighten, this will preserve the spring washers.



Fitting Note:

Where a wind deflector is used, we recommend a minimum of 15mm clearance from the vehicle roof.

Where necessary manually adjust the wind deflector or wind deflector mountings as required.

Thank you for your purchase.

Please complete your warranty application following correct installation.

Wedgetail by Tradesman Roof Racks

Innovation through Inspiration

Congratulations on the purchase of your Australian made Wedgetail Roof Rack product.

Please read and follow the instructions carefully to ensure correct fitment.

Contact us if any parts appear missing, incorrect, or damaged.

Contact us if any question about the size of platform to ensure the correct fitment

Scan QR code for a fitting demonstration



Tools Required:

- Hex key (5mm)

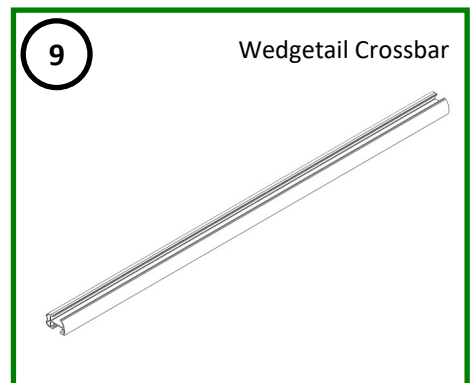
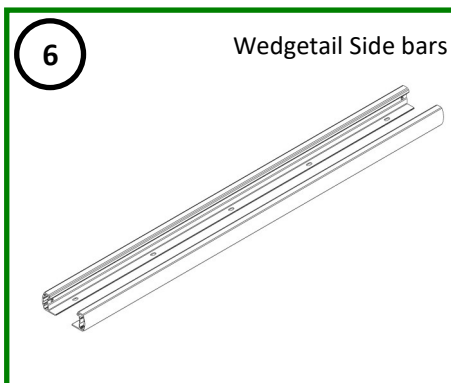
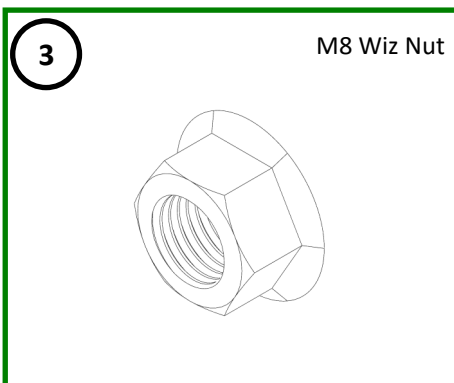
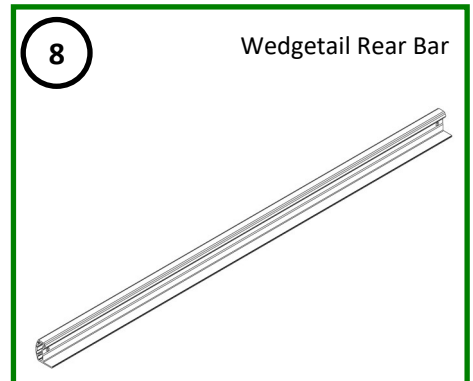
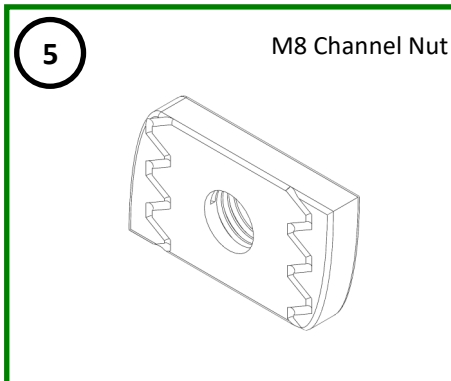
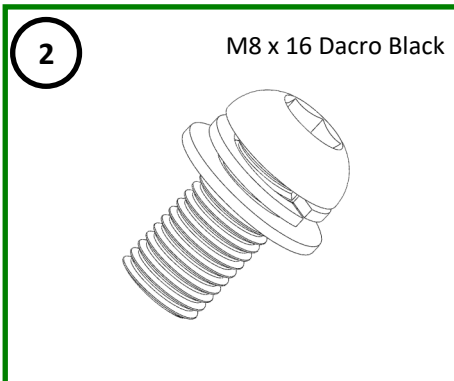
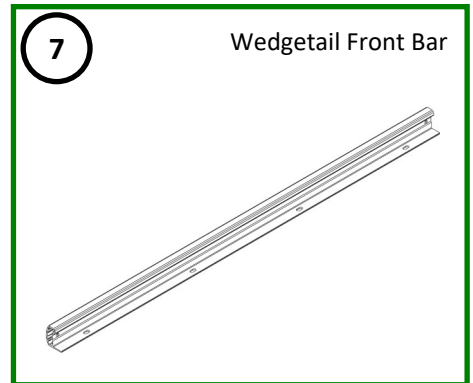
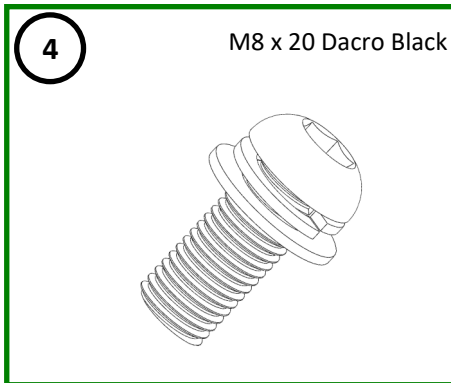
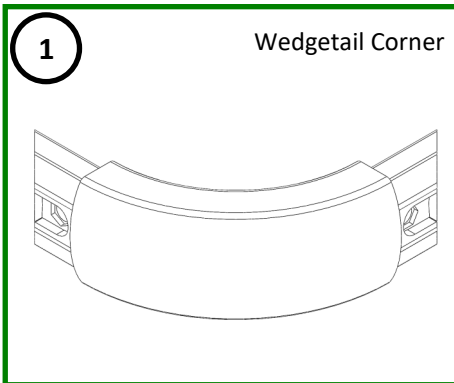

Note:

The amount of components and length of the platform are different based on the platform size ordered.

Please refer to table on Page 2 and confirm before assembly. If any question, please contact our team member.

Wedgetail Platform Fitting Instruction



WTP

KIT CONTENTS									
<u>Item</u>	<u>1</u>	<u>2</u>	<u>3</u>	<u>4</u>	<u>5</u>	<u>6</u>	<u>7</u>	<u>8</u>	<u>9</u>
<u>WT Platform Size</u>	<u>WT Corners</u>	<u>M8 x 16 Dacro Black</u>	<u>M8 Wiz Nut</u>	<u>M8 x 20 Dacro Black</u>	<u>M8 Channel Nut</u>	<u>WT Sides</u>	<u>WT Front Bar</u>	<u>WT End Bar</u>	<u>WT Crossbar</u>
0814	4	8	8	6	6	2	1	1	3
1112, 1113,1119				8	8				4
1411,1412,1413, 1414,1415,1416, 1513				10	10				5
1613,1614,1812, 1813				12	12				6
2012,2013,20135 ,2014,2019				14	14				7
2212,2213,2214				16	16				8
2514,2516				18	18				9
2814				20	20				10
3014,3015,3016, 3316				22	22				11
3616				26	26				13
4015				28	28				14
4215				30	30				15
4614,4615				32	32				16
5014				38	38				19

1

- Assemble your Wedgetail roof rack on a soft surface or blanket to avoid damage to powder coat finish.

2

- Arrange the front, rear, side bars and corners as per figure 1 to begin assembling the perimeter section.

3

- Place the flange nut in the recess as shown in the diagram (flange outwards).

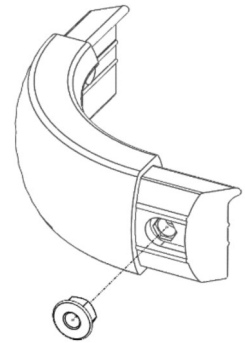

Item used in this step	
Item 1	WT Corner
Item 3	M8 Wiz Nut

4

- Hold the flange nut within the recess and insert it into the perimeter extrusion. Use a soft mallet if required. Repeat the process for all 4 corners.

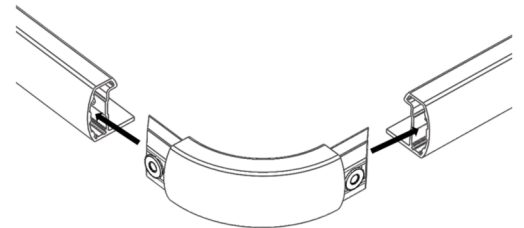

Item used in this step	
Item 1	WT Corner
Item 3	M8 Wiz Nut
Item 6	WT Sides
Item 7	WT Front
Item 8	WT End

5

- Fasten all the corners to the bars using M8X16 bolt and washer. Note: Take care not to cross thread when fastening.

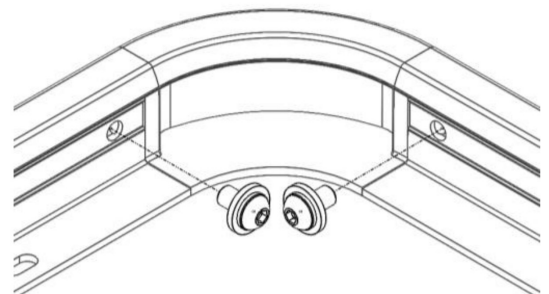

Item used in this step	
Item 2	M8 X 16 Dacro Black

6

- Now turn the rack upside down to access slotted holes for crossbar fitment.

7

- Insert the crossbars within the recess of perimeter extrusion. The crossbar should face forward as shown for best noise and wind resistance.

Front with Wind Deflector slots

Item used in this step	
Item 9	CrossBar

8

- When assembling refer to the image below for right crossbar orientation.

Underside of platform

Underside of platform

This side faces front of the vehicle

9

- Insert the remaining crossbars to the platform.

10

- Fasten the M8 X 20 bolt & washer and the channel nut.

NOTE-Ensure the channel nuts are 90 degrees to the channels.



Check fastenings are firmly tensioned at regular intervals.

Do not overtighten, this will preserve the spring washers.

Item used in this step	
Item 4	M8 X 20 Dacro Black
Item 5	M8 Channel Nut

Thank you for your purchase.

Wedgetail by Tradesman Roof Racks

Innovation through Inspiration