

# Wedgetail Rails and Platform Fitting Instruction

To suit—Toyota Prado 250 LWB 2024-On



WT-TP250-2213

## Congratulations on the purchase of your Australian made Wedgetail Roof Rack product.

Please read and follow the instructions carefully to ensure correct fitment.

Contact us if any parts appear missing, incorrect, or damaged.

Clean the roof prior to fitting the roof racks.

Scan QR code for a fitting demonstration

### Tools Required:

- Hex key (5 & 6 mm)
- Spanner (13 & 17 mm)
- Silicone/urethane sealer

### Kit Content

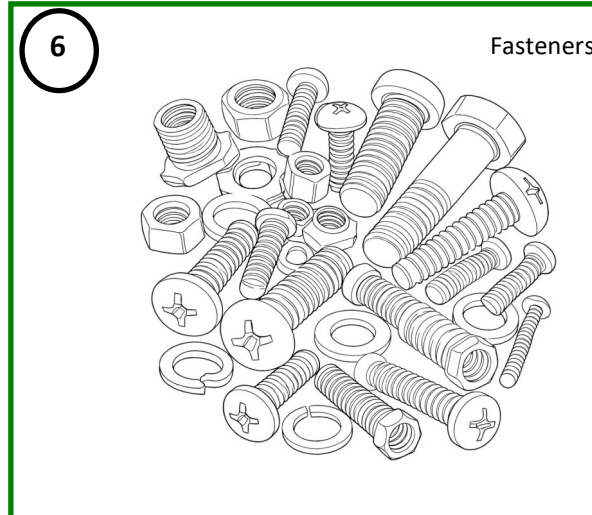
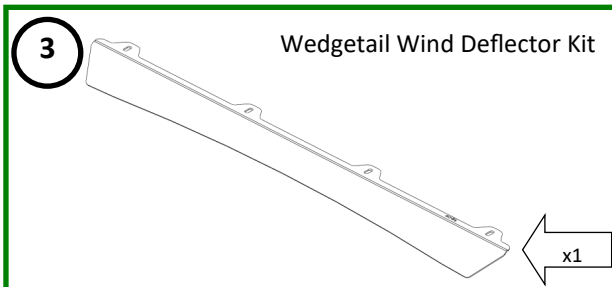
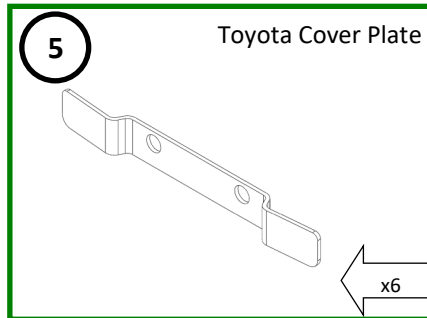
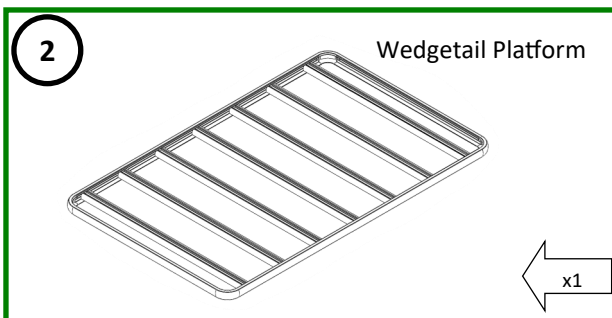
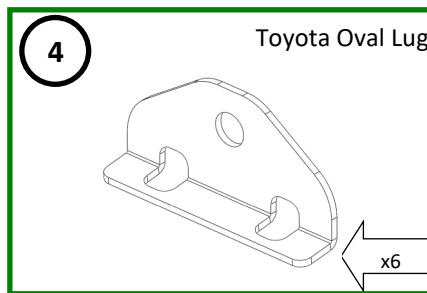
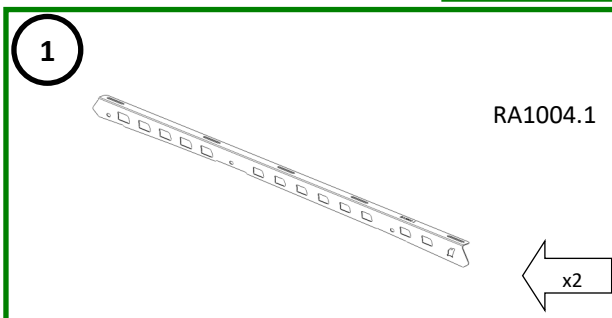

## Factory Rail Removal (Please proceed to step 5 if vehicle has slimline factory rails or No rails )

1

- Remove plastic caps from factory rails to expose the factory mounting point

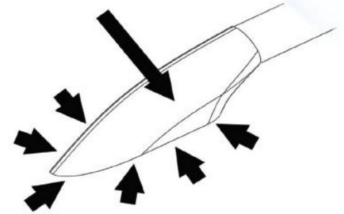

2

- Using a flat head screw driver place in the join between the plastic cap and backing plate. Pull cover outwards until clips let go.

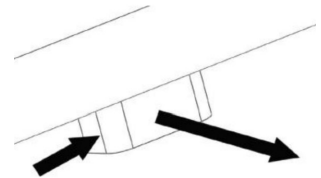

3

- Removing the centre mount cover use a small flathead screwdriver place in the side of the mount between the plastic cover and the metal part of the rail. Pull the plastic out towards you until the clips let go.

4

- Undo mounting bolts (WARNING, LOOSEN ALL BOLTS FIRST THEN REMOVE, DO NOT LOOSEN AND REMOVE ONE BOLT AT A TIME AS THIS MAY CAUSE THE RETAINING PLATES TO DROP INSIDE THE ROOF LINING). Lift rails off and discard, leaving the rubber channel strips in place. Remove cover strip in roof channel just back from the front mount and remove both bolts (loosen both bolts first then remove). Discard all mounting hardware. Go to step 6.

## Removing factory slim line rails / mount points fastenings

5

- Remove plastic cover strips in the roof channels, pushing them forward (locate small slot in cap, insert flat screwdriver to lever up ) Then remove all bolts in roof (WARNING, LOOSEN ALL BOLTS FIRST THEN REMOVE, DO NOT LOOSEN AND REMOVE ONE BOLT AT A TIME AS THIS MAY CAUSE THE RETAINING PLATES TO DROP INSIDE THE ROOF LINING), discard all hardware removed.

6

- Apply silicone or urethane sealer (natural cure sealants only) to the mounting holes.
- Fit 6 rail mounting lugs and cover plates using 8mm hardware (as per diagram below).

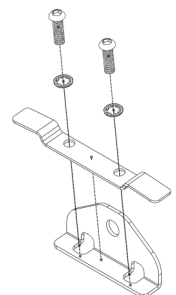

7

- Attach rails to the lugs using 10mm hardware (as per diagram below). Do not fully tighten.

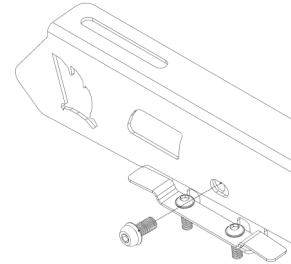

8

- Attach the channel nuts to the top of rail.
  - Fit 10mm Bolt / Split washer / Flat washer / Channel Nuts to the top of rail.

\* Channel nuts to the top as shown in the following diagram

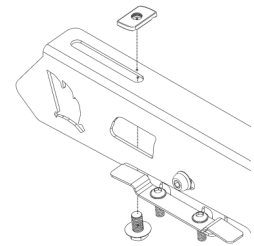

## Assemble the Wedgetail Platform to the rails

9

- Place the Wedgetail Platform on the rails (Wind Deflector mounting towards the front of vehicle), then spin the channel nuts 90 degrees in the channel on the underside of the rack till they lock into the channels. Don't tighten fully

10

- Centralize the rack side to side (using a tape measure) on the wedgetail rails.

11

- Fully tighten remaining bolts in the following order:

1. Rails to the lugs
2. Rails to platform
3. Attach wind Deflector.

**NOTE**-Ensure the channel nuts are 90 degrees to the channels.



Check fastenings are firmly tensioned at regular intervals.

Do not overtighten, this will preserve the spring washers.



**Fitting Note:**

Where a wind deflector is used, we recommend a minimum of 15mm clearance from the vehicle roof.

Where necessary manually adjust the wind deflector or wind deflector mountings as required.

Thank you for your purchase.

Please complete your warranty application following correct installation.

Wedgetail by Tradesman Roof Racks

Innovation through Inspiration